

# Spindle motor

with manual tool changer

## iSA 1500 L



iSA 1500 L with manual tool change

### Technical specification

| Description                       |       | iSA 1500 L     |
|-----------------------------------|-------|----------------|
| Torque at rated speed 6,000 rpm   | [Nm]  | 2.37           |
| Speed range                       | [rpm] | 2,500 to 6,000 |
| Cut-off frequency                 | [Hz]  | 107            |
| Number of poles                   |       | 2              |
| Rated voltage                     | [V]   | 200            |
| Rated current                     | [A]   | 6.5            |
| cos $\phi$                        |       | 0.84           |
| Rated power (S 6 = 40% operation) | [W]   | 1500           |
| Concentricity                     | [mm]  | 0.01           |
| Weight                            | [kg]  | 10.5           |

### Dimensioned drawings

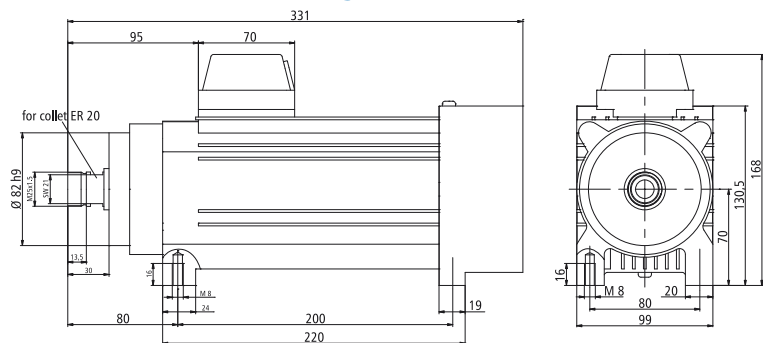

### Torque curves

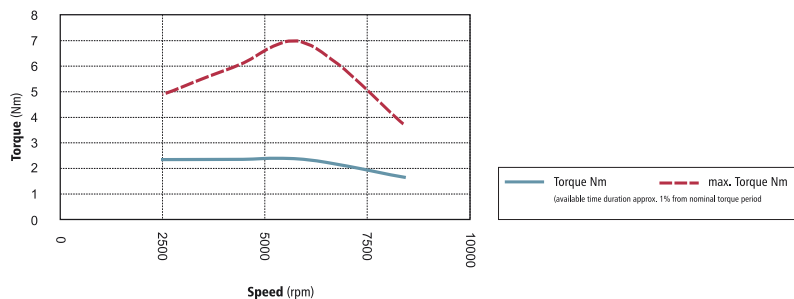

### Features

- Robust 2-pole AC motor
- Protection class IP54, insulation class F
- Motor shaft to take ER 20 collets
- Cast bearing apron A and B sides
- Rated output 1.5 kW (S6-40% operation)
- Rotational speed range 2,500 rpm – 6,000 rpm
- Torque 2.37 Nm (at 6,000 rpm)
- Rated voltage 200 V
- Manual tool change
- Clamping range  $\varnothing$  2 mm –  $\varnothing$  13 mm
- Intrinsic ventilation B-side
- Controlled by frequency converter
- Spindle bearing:
  - A-side (milling side) double,
  - B-side (ventilation side) single
- Concentricity: 0.01 mm
- Weight: 10.5 kg
- **Optional:**
  - CoolMin® Tool and material cooling, external
  - Frequency converter
  - collets

### Ordering information

iSA 1500 L spindle motor with collet ER 20 (6 mm), clamping key ER 20, jaw key SW 22, Interconnectron connection  
Part no.: **477510 3106**

iSA 1500 L spindle motor with converter with collet ER 20 (6 mm), clamping key ER 20, jaw key SW 22, Interconnectron connection  
Connecting leads 8 m  
Part no.: **310610 3615**

CoolMin® external  
Part no.: **239011 0119**

Suction device for EuroMod / FlatCom prepared for 38 mm diameter hose  
Part no.: **239012 0001**

Clamping set ER 20  
2.0 / 3.0 / 4.0 / 5.0 / 6.0 / 7.0 / 8.0 / 9.0 / 10.0 / 11.0 / 12.0 / 13.0 mm  
Part no.: **239172 0001**

Mounting plate isel System (Z axis)  
EuroMod / FlatCom (LES 21)  
Part no.: **277028 0011**

Mounting plate isel System (Z axis)  
Linear unit LES 5  
Part no.: **277028 0005**